

SINGER
46K29,K30

Form K2539
Sup'des K1716
March, 1924

ILLUSTRATED LIST OF PARTS

FOR

Nos. 46K29 and 46K30 MACHINES



THE SINGER MANUFACTURING COMPANY

From the library of: Diamond Needle Corp

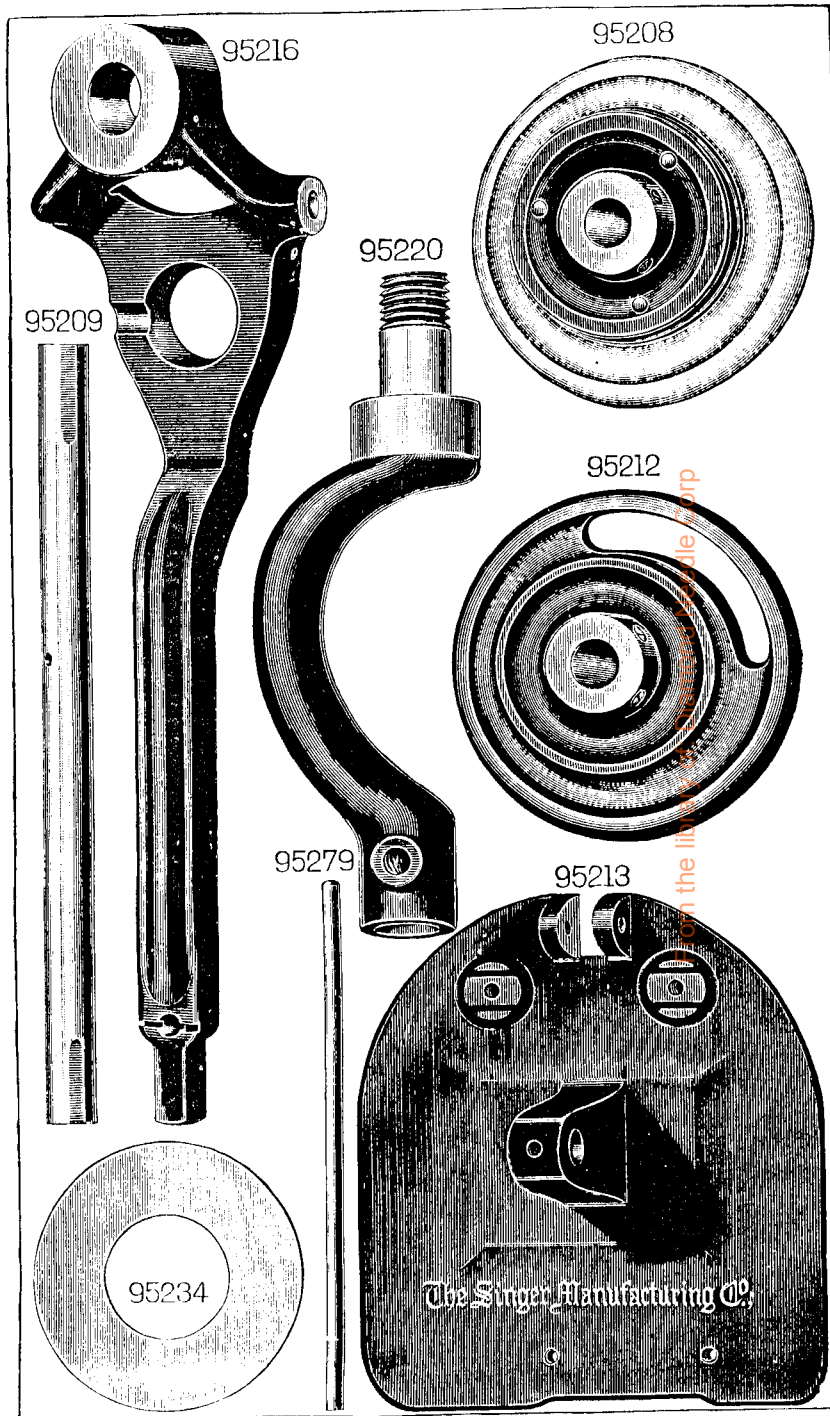

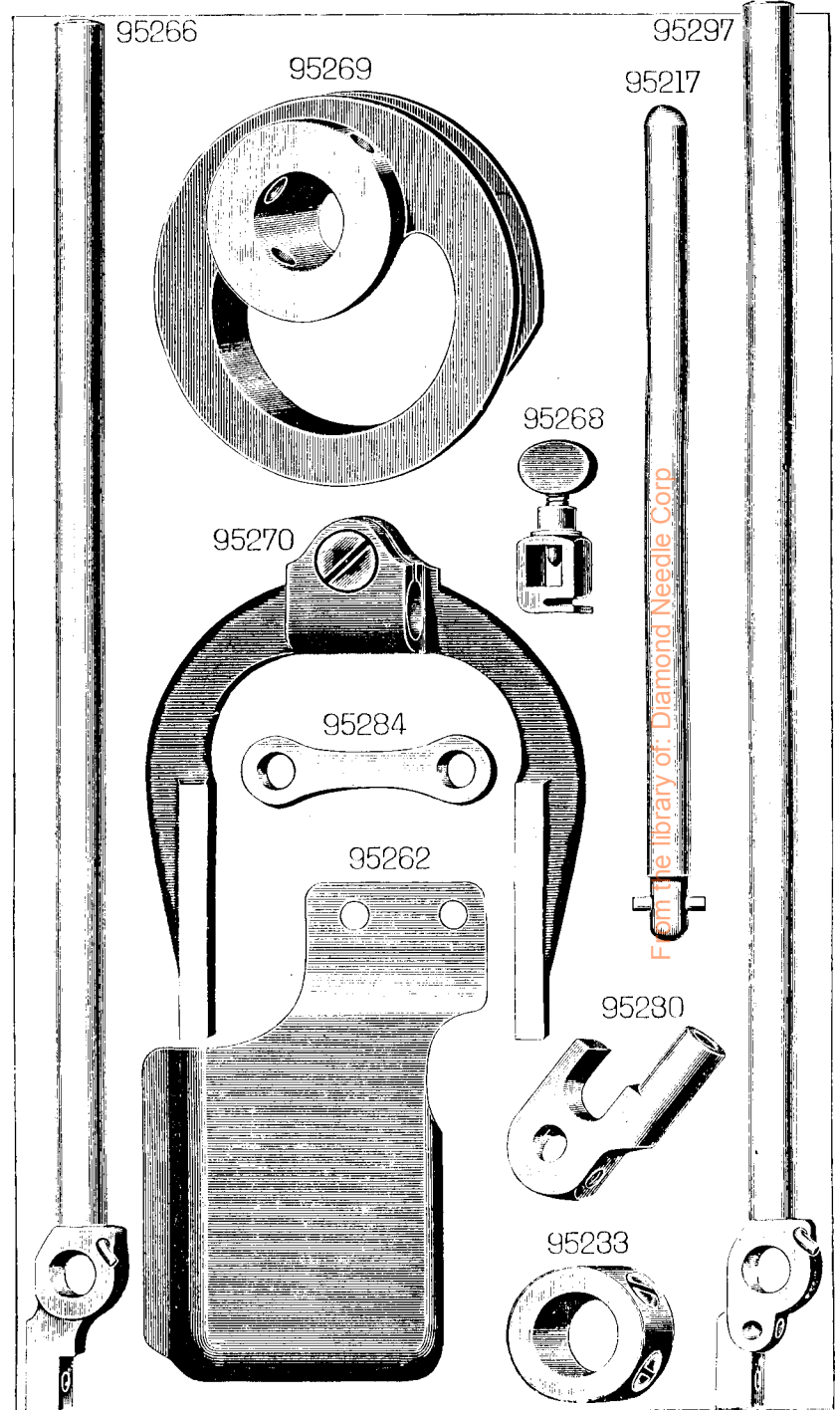
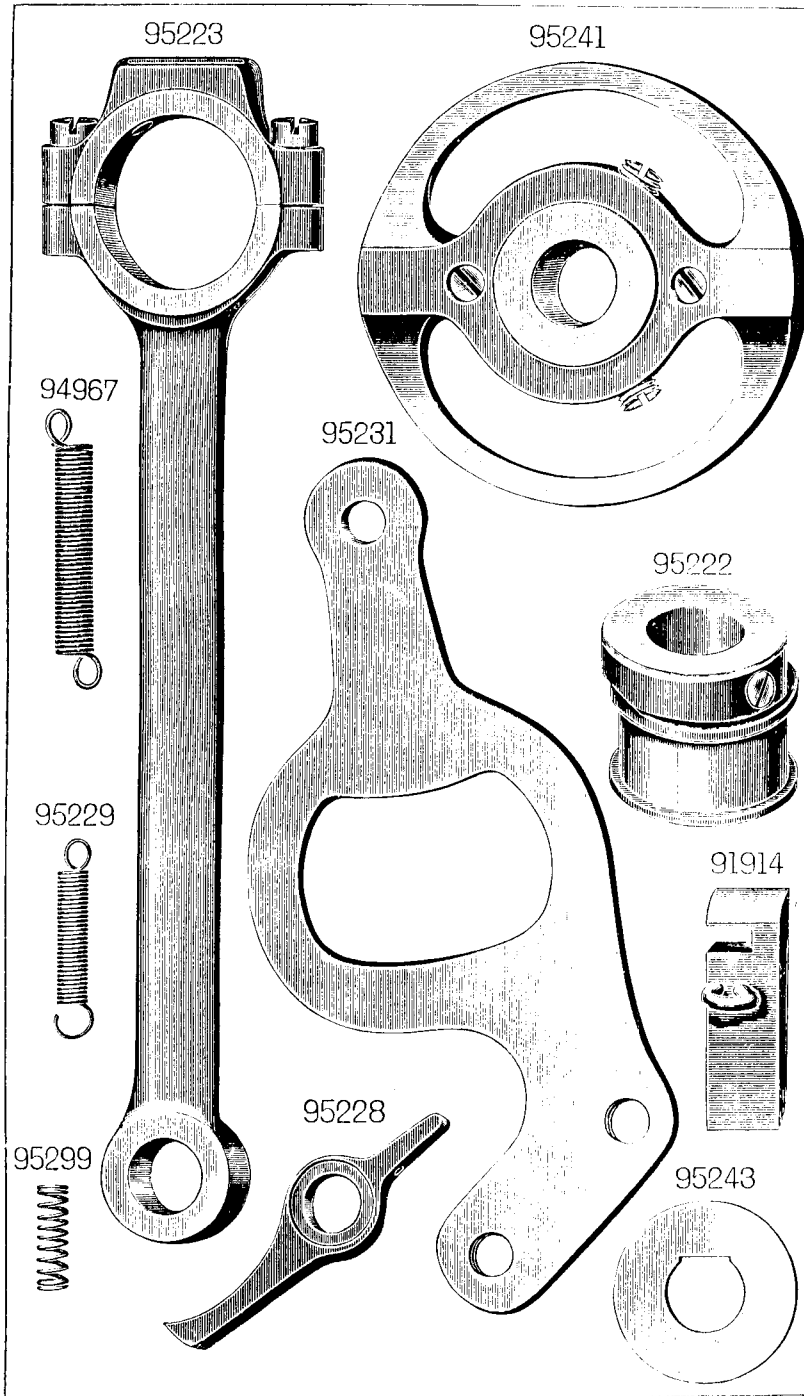

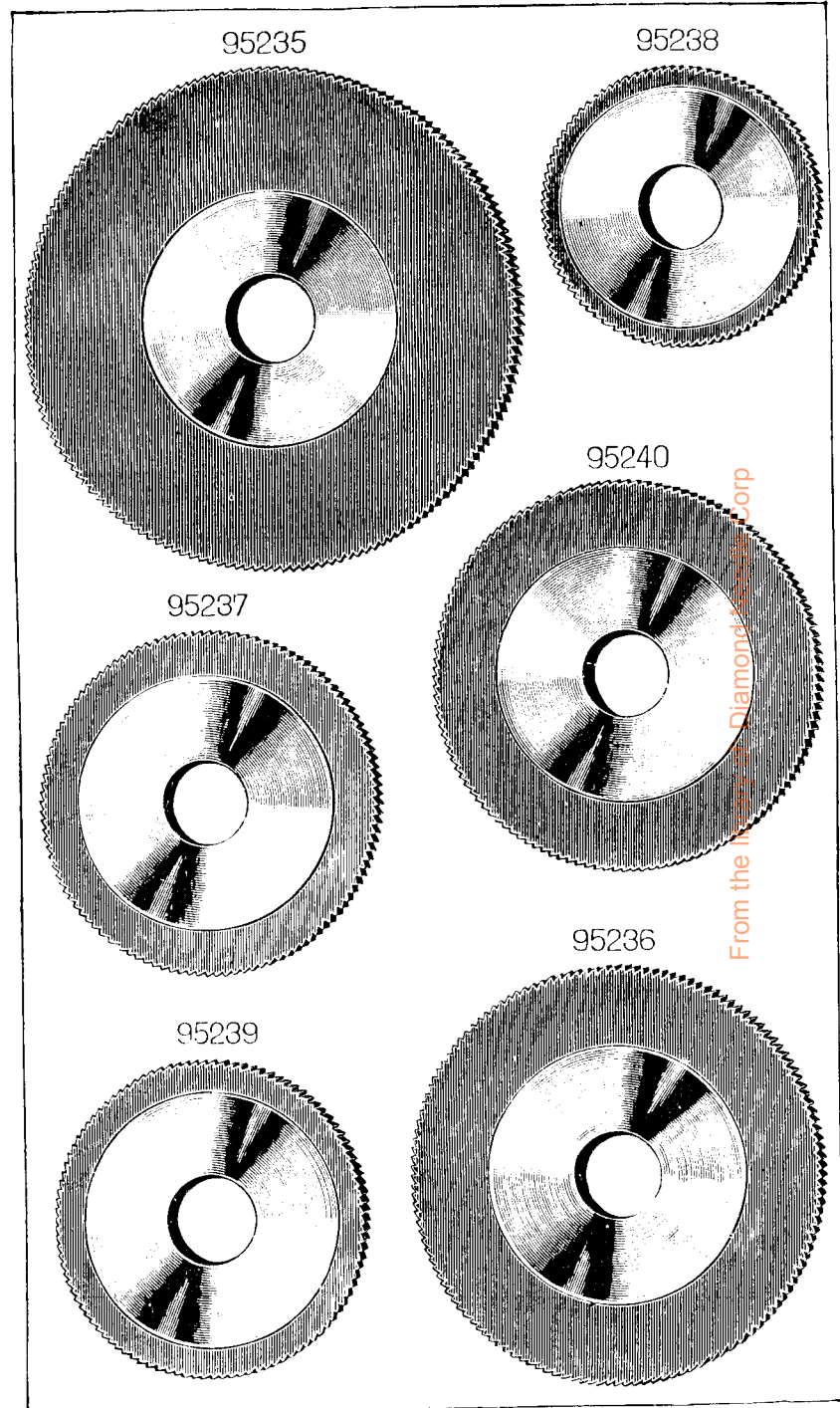
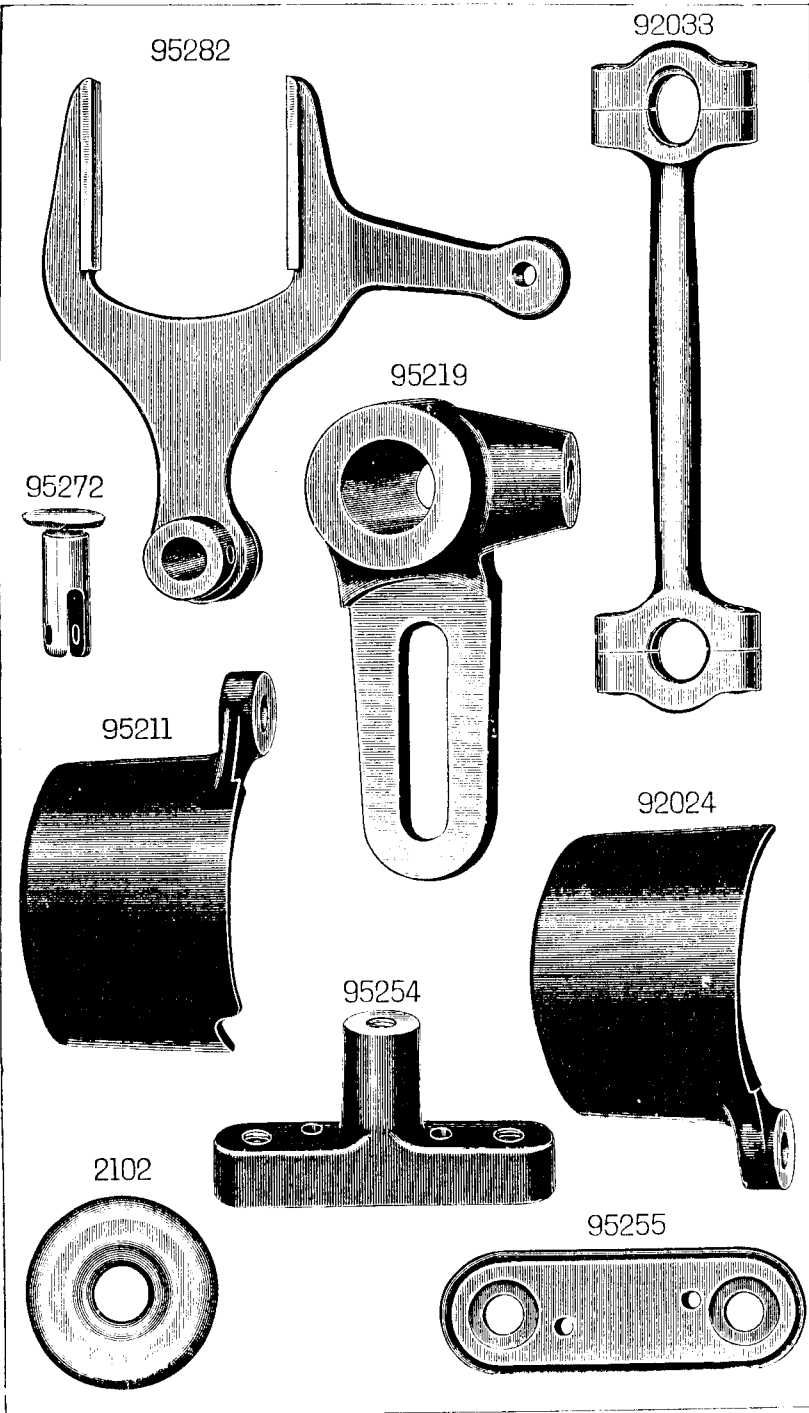

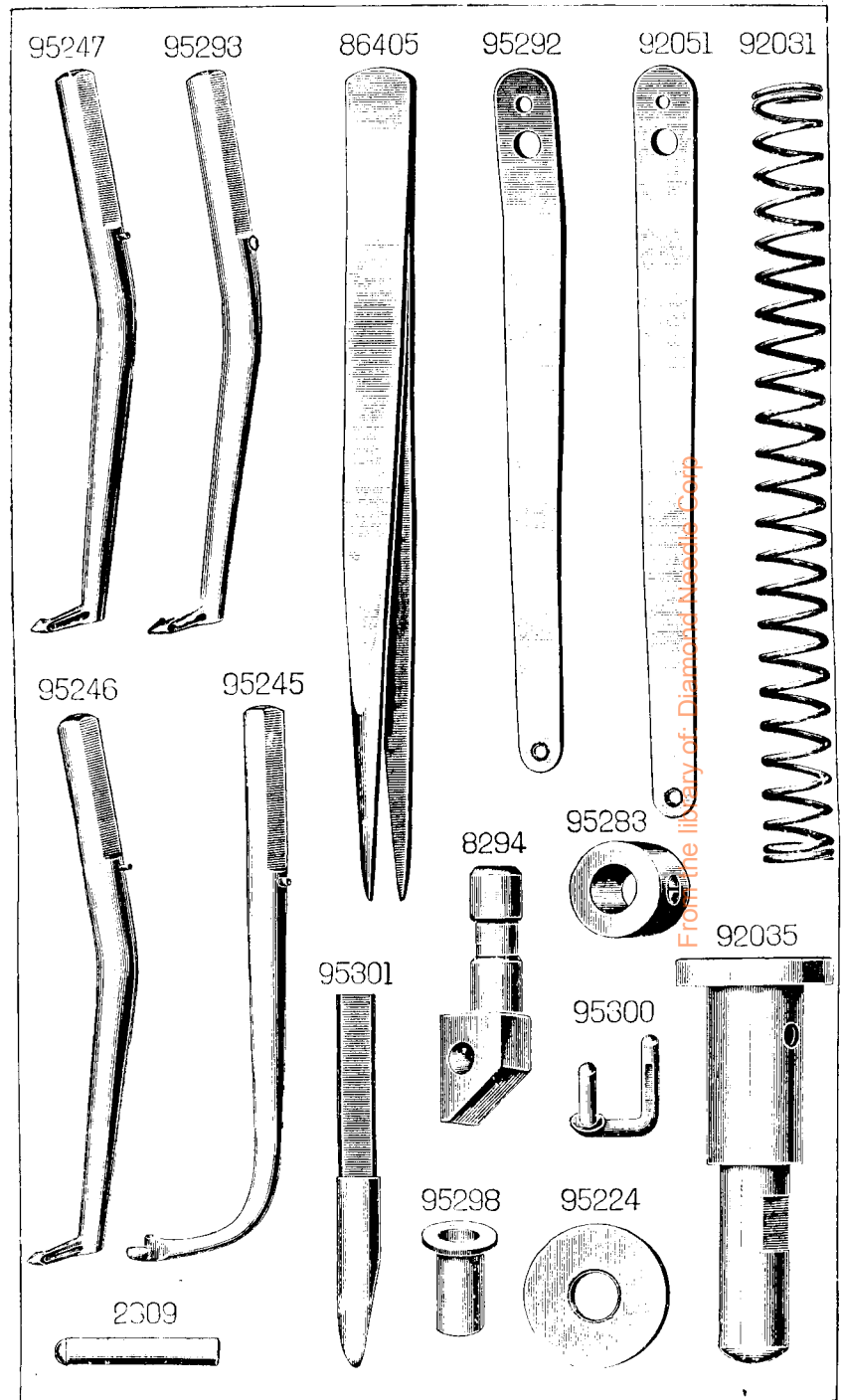
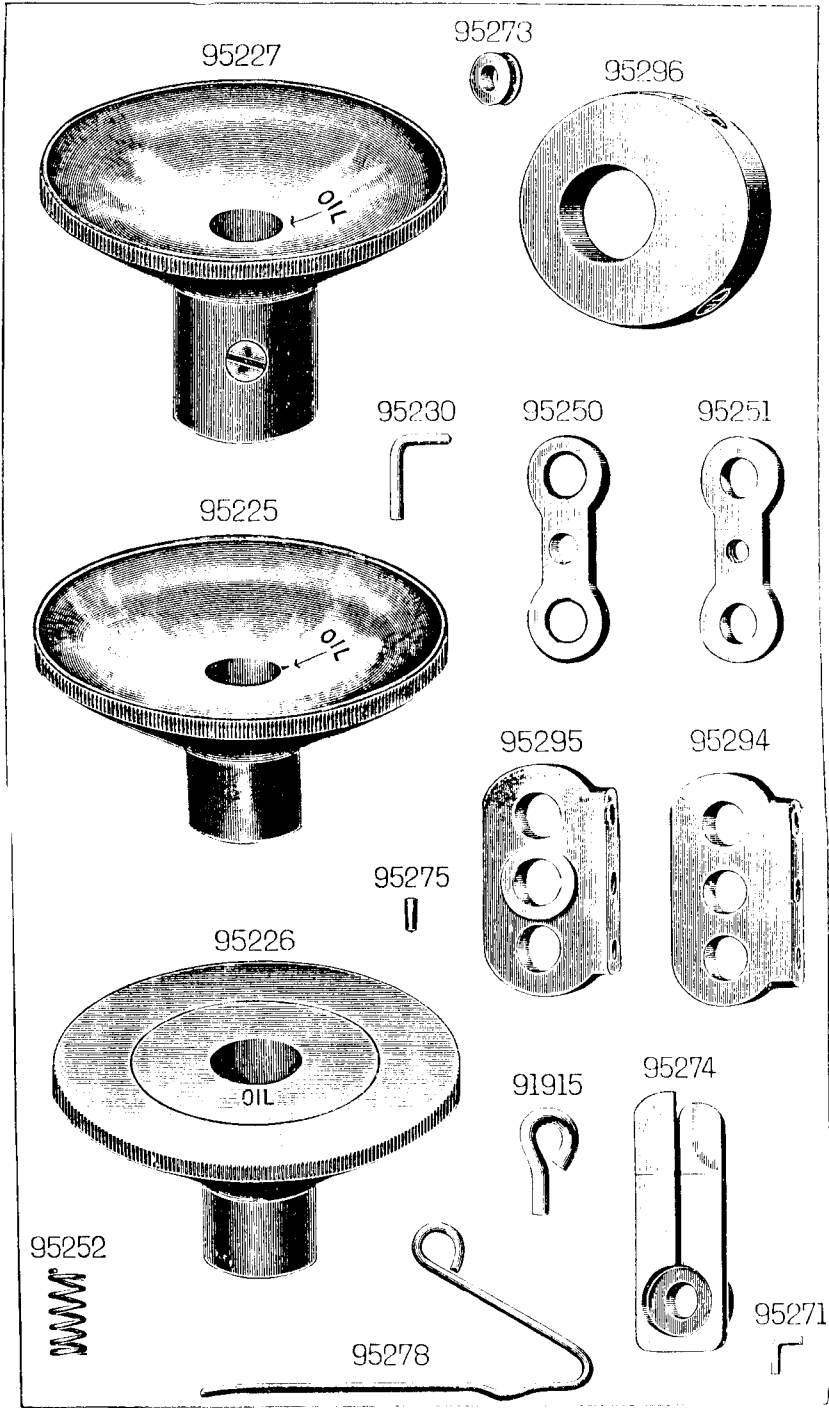

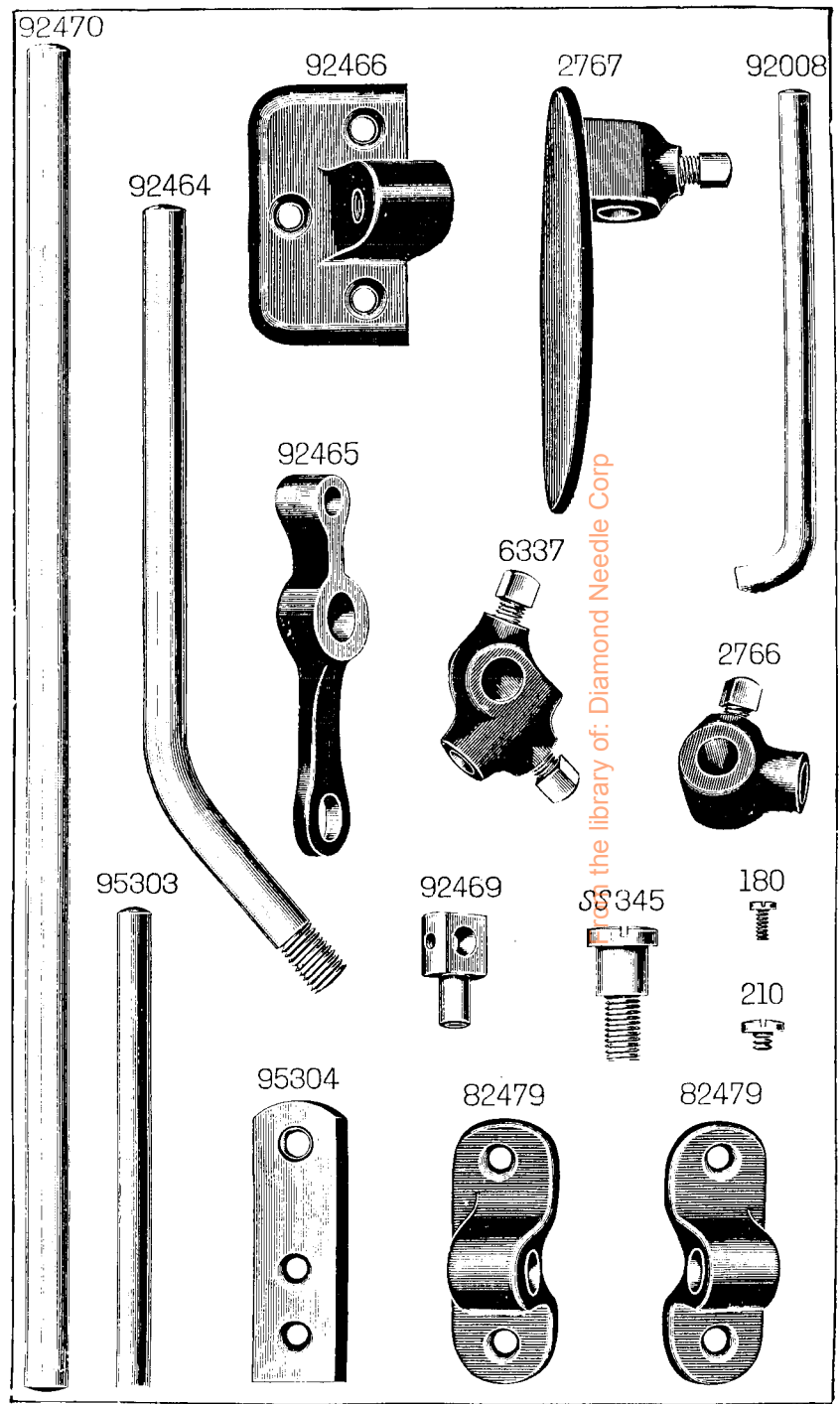
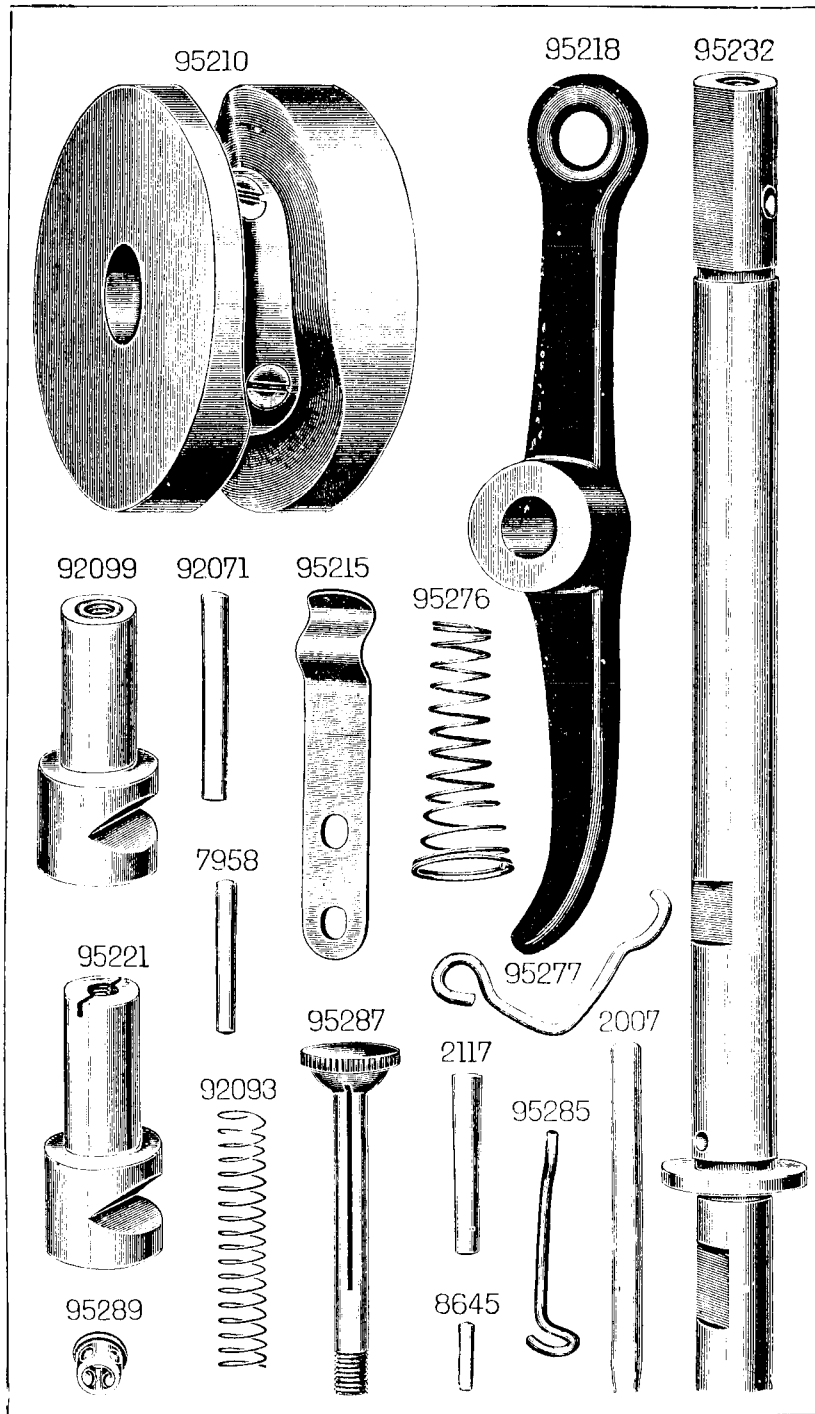

from the library of: Diamond Needle Corp

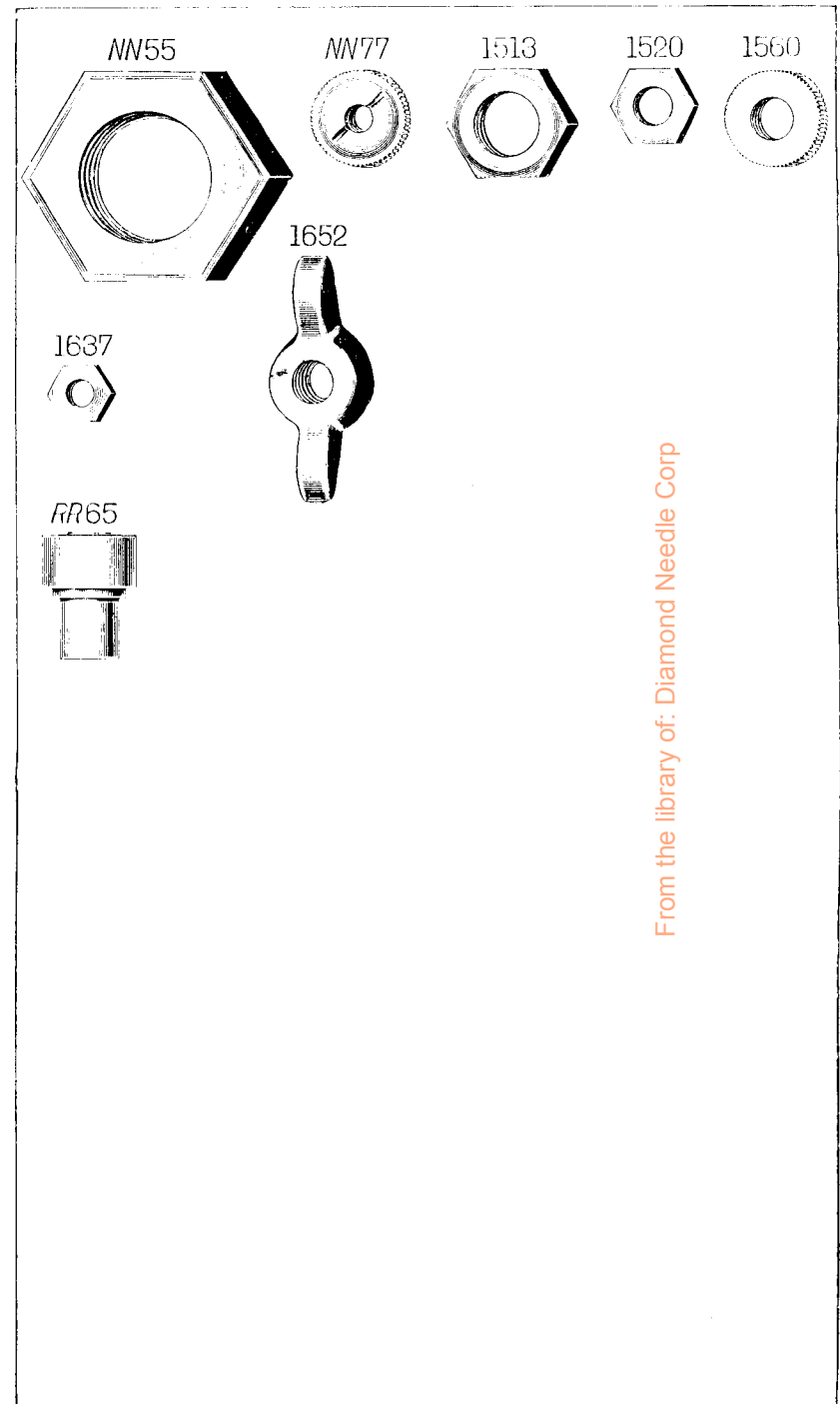
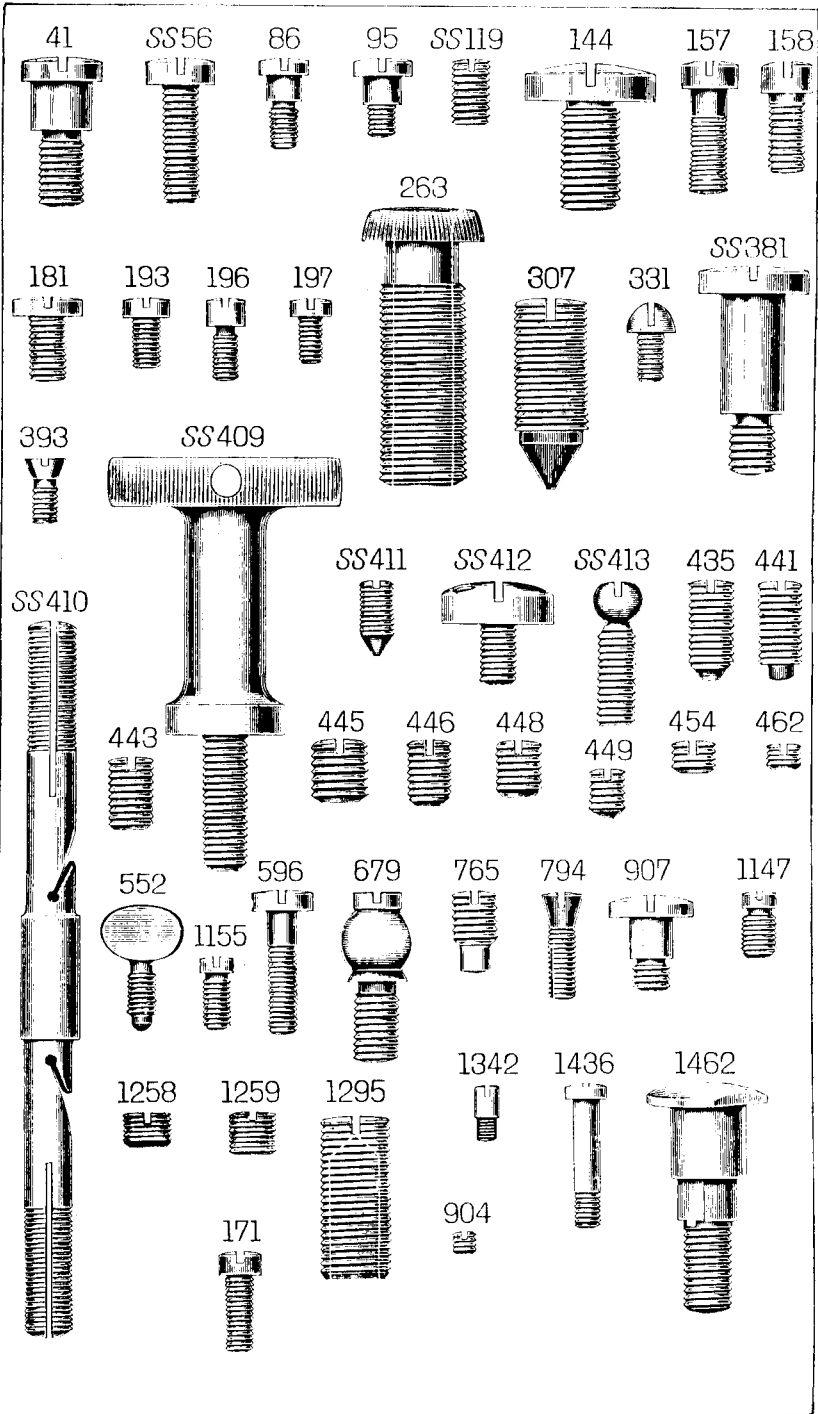

From the library of: Diamond Needle Corp

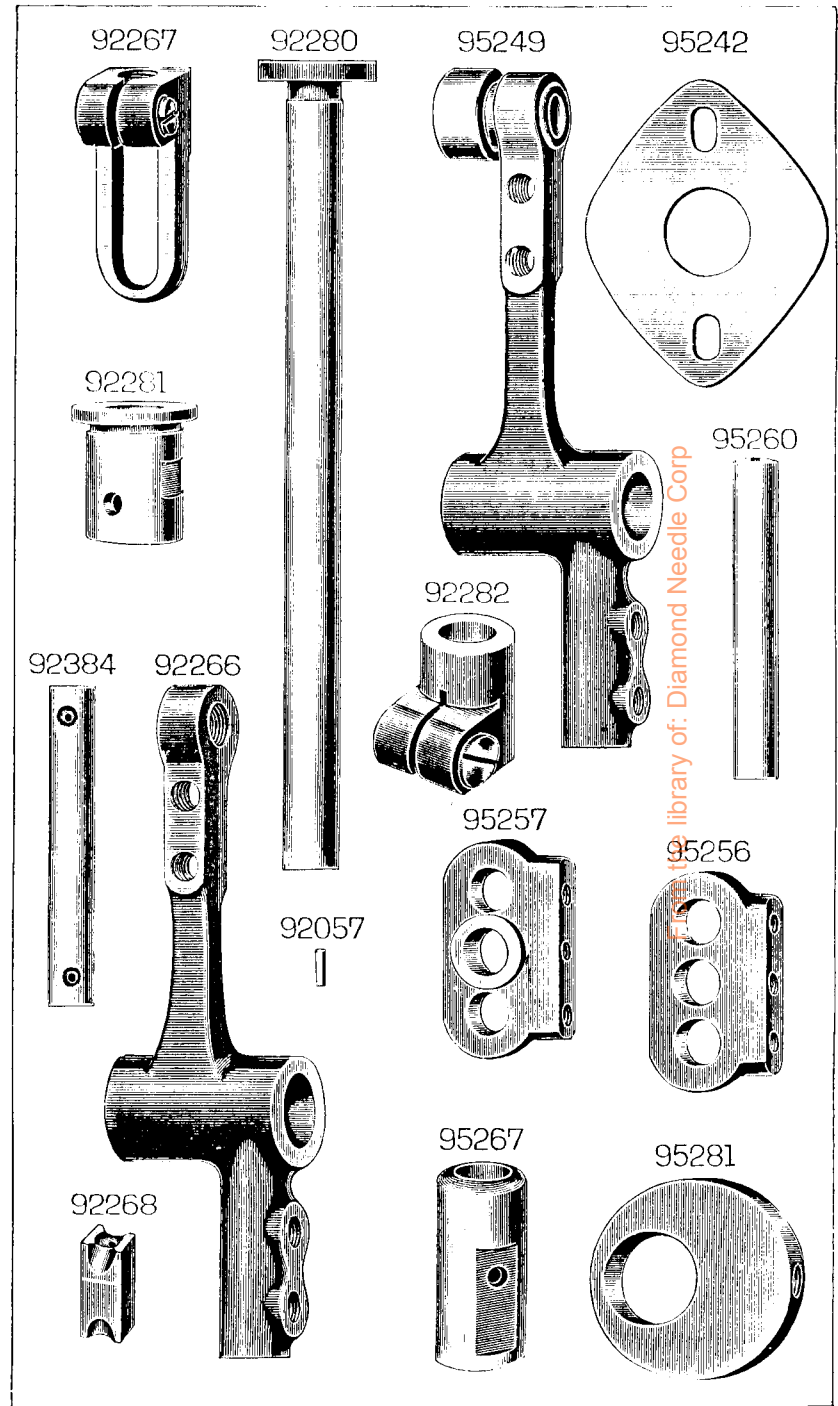
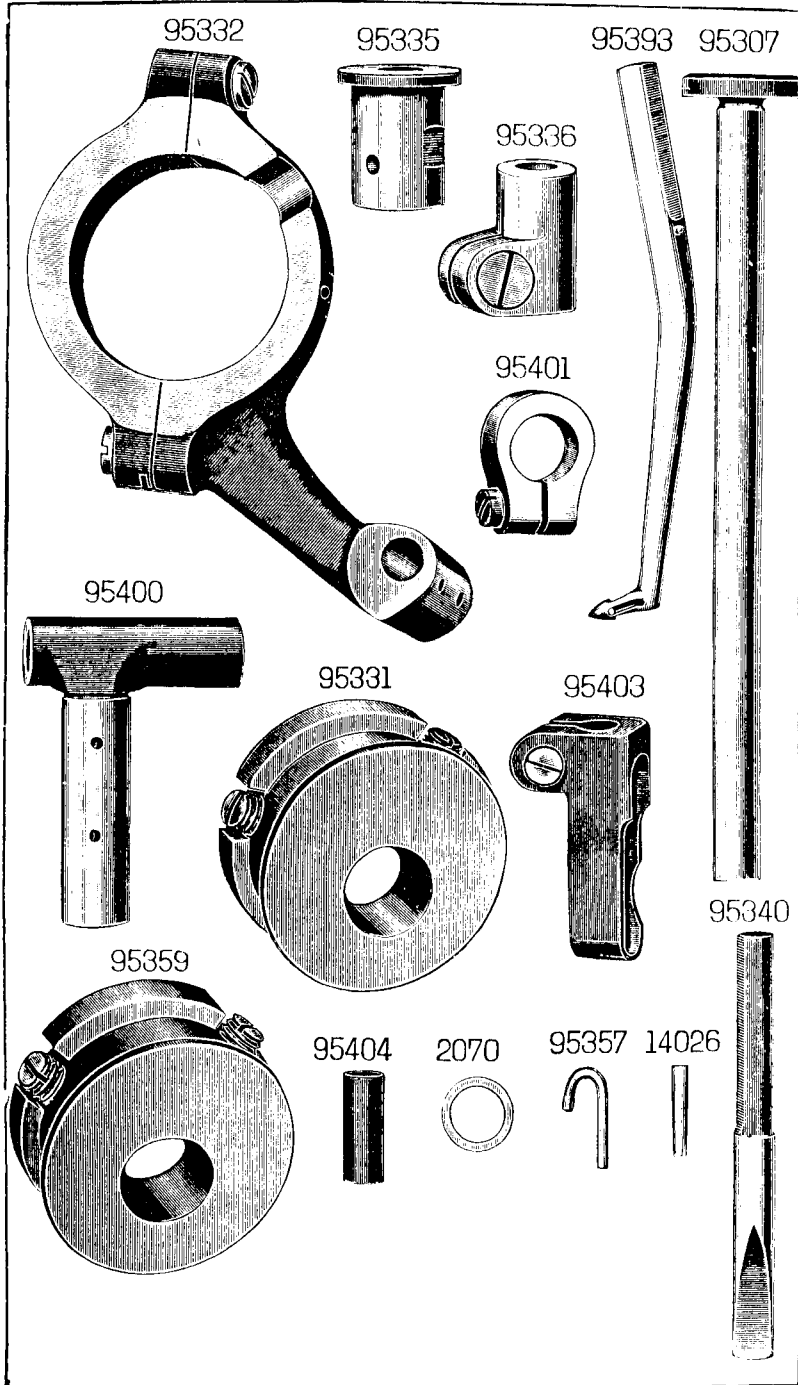

Library of: Diamond Needle Corp

62301

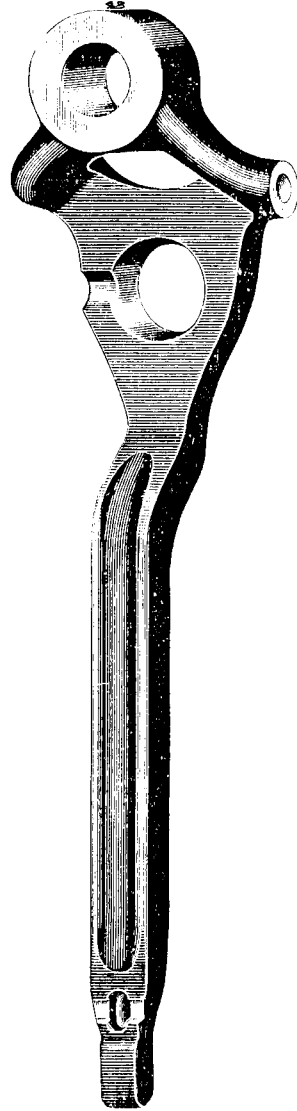

92275

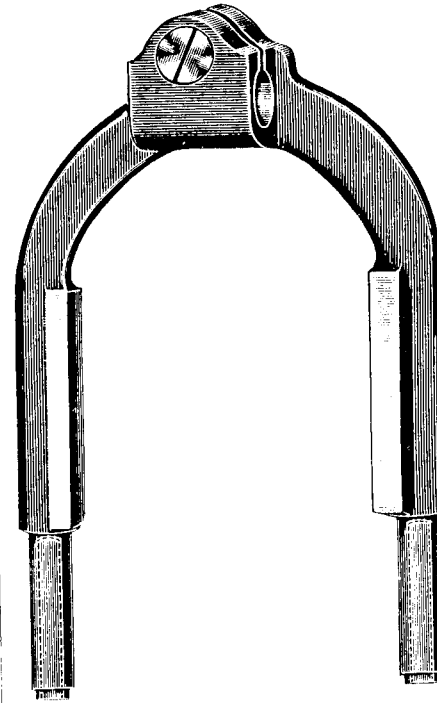

92276

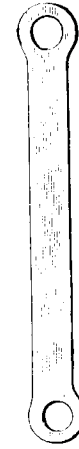

95408

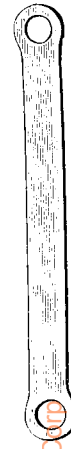

From the library of: Diamond Needle Co.

95395

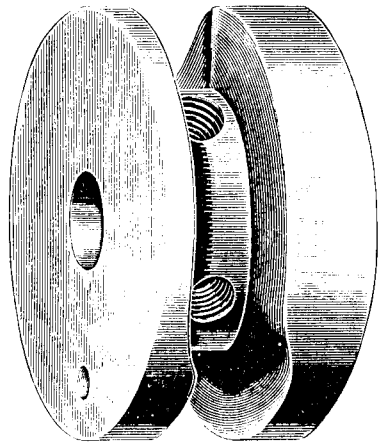

SS488

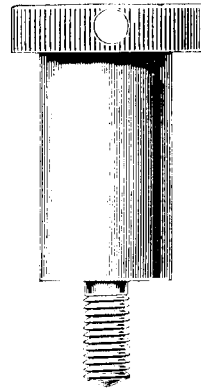

95360

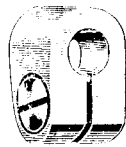

92270

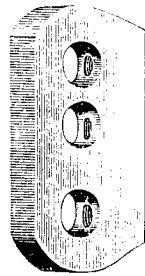

92271

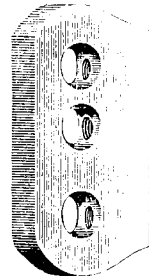

92279

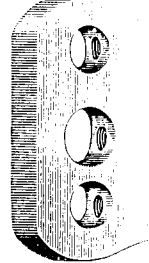

92278



92272

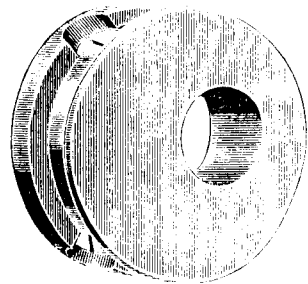

159



175



208



209



356



378



SS437



447



SS467



704



1057



1077



NW82



1550



RR68

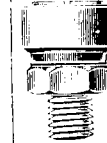

From the library of: Diamond Needle Corp

CONTENTS

	PAGES
Parts Complete for No. 46K29 Machine ...	31
Parts Special to No. 46K30 Machine ...	37
Accessories	42
Knee Lifter	42
Numerical List of Parts	49
Obsolete Parts	45

From the library of: Diamond Needle Corp

ILLUSTRATED LIST OF PARTS

FOR

Nos. 46K29 and 46K30 MACHINES



In ordering from this List, the prefix and affix letters with the part number **MUST BE** quoted exactly as they are shown in the first column.

A number always indicates the same part in whatever List it may appear, or for whatever machine.

The prefix *SS* indicates Screws made only at Singer.

" " *NN* " Nuts made only at Singer.

" " *RR* " Rollers and Studs made only at Singer.

The affix letters (where shown) indicate the style of finish, as follows:—

- A.** Hardened, Polished and Plated.
- B.** Polished and Plated.
- C.** Hardened only.
- D.** Polished only.
- E.** Soft, not Polished.
- F.** Hardened and Polished.
- H.** Blued.
- J.** Plated only.
- K.** Hardened and Plated.
- L.** Brass or Gilt.
- M.** Oxidized.
- R.** Parkerized.
- T.** Copper Plated.

In this series

- 1 to 1500 and 5000J to 51500 are Screw Numbers.
- 1501 " 1800 are Nut Numbers.
- 1801 " 2000 " Roller Numbers.
- 2001 " 50000 are numbers of machine parts, etc.
- 80001 " 100000 are numbers of machine parts, etc.
made only at Singer.

Parts marked with an asterisk () are furnished only when the repairs are made at Factory.*

PARTS COMPLETE

FOR

No. 46K29 Machine



For Fine Glove Work with "Round Seam" stitch (Surjeteuse). This machine is fitted with Ratchet Feed Motion and is supplied with three ratchet wheels having 116, 140 and 165 teeth, for 18, 22 or 26 stitches to the inch, for single or double chain stitch.

No.	Plate	
95206	-	Balance Band Wheel Pulley with two 448c
448c	1024	" " " " Set Screw
95207	---	" " " " Rim (Wood)...
596d	1024	" " " " Binding Screw
95208	1014	Balance Band Wheel, complete, Nos. 95206, 95207 and three 596d
95209	1014	Balance Band Wheel Shaft
144d	1024	" " " " End Screw (2)...
95395	1494	" " " " Loper Cam (Steel) with two 445c
445c	1024	" " " " " " Set Screw
95211	1017	" " " " " Oil Hole Cover (right)
92024	1017	" " " " " " " " (left)
86d	1024	" " " " " " " " Hinge Screw
95212	1014	Balance Hand Wheel with two 448c
448c	1024	" " " " Set Screw
95213	1014	Cover Plate
95214	---	Cover Plate, complete, Nos. SS410f, 8645, 92051, 95213, 95290, two each 331d, 1560d, 95276 and four 2102
2117	1022	Cover Plate Hinge Pin
95215	1022	" " " " Latch Spring
193f	1024	" " " " " Screw (2)

PARTS COMPLETE FOR No. 46K29 MACHINE

No.	Plate				
62301	1492	Feed Adjusting Lever with 446c ...			
307c	1024	" " " Screw Centre (2) ...			
1513j	1025	" " " " " Nut (2) ...			
446c	1024	" " " Set Screw ...			
95217	1016	" " " Spindle with 14026 ...			
14026	1162	" " " " " Position Pin ...			
92031	1021	" " " " " Spring ...			
263e	1024	" " " " " Regulating Thumb Screw ...			
2070	1162	" " " " " Washer ...			
95219	1017	Feed Bell Crank ...			
*92017	—	" " " " Connecting Rod ...			
92033	1017	" " " " " 92017 with 92034, 92256 and four 196f			
*92034	—	" " " " " Cap (plain countersink) (for Pawl Plate Universal Joint Screw)			
*92256	—	" " " " " Rod Cap (elongated countersink) (for Bell Crank Universal Joint Screw)			
196f	1024	" " " " " Rod Cap Binding Screw ...			
92035	1021	" " " Fulcrum Stud ...			
448c	1024	" " " " " Set Screw ...			
679c	1024	" " " Universal Joint Screw ...			
95220	1014	Feed Bracket (front) ...			
95234	1014	" " (") Dust Guard Washer ...			
NN55c	1025	" " Nut ...			
95221	1022	" " Stud ...			
92099	1022	" " " for Flat Top Feeding Disc (front)			
SS411c	1024	" " " Raising Set Screw ...			
445c	1024	" " " Set Screw ...			
95222	1015	Feed Eccentric with 448c ...			
95223	1015	" " Connecting Rod with 80358 and two 159c ...			
*80358	—	" " " " Cap ...			
159c	1495	" " " " " Screw ...			
1462f	1024	" " " " " Hinge Screw ...			
1652j	1025	" " " " " " Nut ...			
95224	1021	" " " " " " Washer ...			
448c	1024	" " " Set Screw... ...			
95225	1020	Feeding Disc (front) ...			
95226	1020	" " (") with flat top ...			
NOTE--No. 95225 is sent with this machine unless other Feeding Disc is specified on order.					
95227	1020	Feeding Disc (back) with 454c ...			
454c	1024	" " Set Screw ...			

PARTS COMPLETE FOR No. 46K29 MACHINE

No.	Plate				
95228	1015	Feed Ratchet Pawl ...			
41c	1024	" " " Hinge Screw ...			
1520e	1025	" " " " " Nut ...			
95231	1015	" " " Plate ...			
907d	1024	" " " " " Hinge Screw ...			
679c	1024	" " " " " Universal Joint Screw ...			
1520e	1025	" " " " " " " Nut... ...			
95229	1015	" " " Spring ...			
95230	1020	" " " " " Hook ...			
95232	1022	Feed Ratchet Shaft (upright) ...			
95233	1016	" " " Position Collar with 1258c and 1259c ...			
1258c	1024	" " " " " Set Screw (short) ...			
1259c	1024	" " " " " " (long) ...			
91914	1015	" " Shaft Retaining Clutch with 91915 ...			
94967	1015	" " " " " Spring... ...			
91915	1020	" " " " " Hook ...			
95230	1020	" " " " " " " (for machine head)			
95241	1015	" " " " " Wheel with 435c, 441c and two 765c			
95242	1491	" " " " " Friction Spring ...			
95243	1015	" " " " " " Washer ...			
765c	1024	" " " " " Spring ...			
435c	1024	" " " " " Tension Screw ...			
441c	1024	" " " " " Set Screw ...			
SS488d	1494	" " " " " Position Screw ...			
95235	1019	" " Wheel, 165 teeth ...			
95236	1019	" " " 140 " ...			
95237	1019	" " " 116 " ...			
95238	1019	" " " 94 " (for E'port) ...			
95239	1019	" " " 106 " (" ") ...			
95240	1019	" " " 130 " (" ") ...			
95218	1022	Feed Roll Opening Lever ...			
SS381d	1024	" " " " " Hinge Screw ...			
92051	1021	Flat Thread Guide Finger (for double chain stitch) ...			
331d	1024	" " " " " Binding Screw ...			
8645	1022	" " " " " Position Pin ...			
95306	—	Head (of machine) ...			
SS56d	1024	" (" ") Binding Screw (2) ...			
95245	1021	Looper with 92057 (single chain) ...			
95246	1021	" " 92057 (double chain, fine) ...			
95247	1021	" " 92057 (" " coarse) ...			
1147c	1024	" Binding Screw (2) ...			

NOTE—No. 95246 is supplied with this machine unless another Looper is specified on order.

No.	Plate						
92266	1491	Looper Holder
92288	—	"	"	92266 with RR68
92267	1491	"	"	Position Link with 171c
95254	1017	"	"	"	"	Bracket	...
95255	1017	"	"	"	"	"	Plate
SS56e	1024	"	"	"	"	"	Binding Screw (2)
7958	1022	"	"	"	"	"	Steady Pin (2)
92268	1491	"	"	"	"	"	Distance Rod
SS437c	1495	"	"	"	"	"	End Screw
171c	1024	"	"	"	"	"	Binding Screw
SS413c	1024	"	"	"	"	"	Universal Joint Screw...
NN82c	1495	"	"	"	"	"	Nut (top)
1637e	1025	"	"	"	"	"	Nut (bottom)
92269	—	Looper Holder Position Link , complete, Nos. SS437c, 92267, 92268, and two SS413c
92271	1494	Looper Holder Rock Shaft Bracket (left side)
92270	1494	"	"	"	"	"	(right side)
SS467c	1495	"	"	"	"	"	(" ") Adjusting Screw
1550j	1495	"	"	"	"	"	(" ") " Screw Nut
1155d	1024	"	"	"	"	"	Set Screw (4)
92272	1494	"	"	"	"	"	Eccentric with two 446c
95332	1162	"	"	"	"	"	Connecting Rod with 95333 and two 1057c
*95333	—	"	"	"	"	"	Connecting Rod Cap
1057e	1495	"	"	"	"	"	Cap Screw
95260	1491	"	"	"	"	"	Stud
446c	1024	"	"	"	"	"	Set Screw
95400	1162	"	"	"	"	"	Fulcrum Joint
95401	1162	"	"	"	"	"	Collar with 171c
171c	1024	"	"	"	"	"	Binding Screw
92384	1491	"	"	"	"	"	Stud
209d	1495	"	"	"	"	"	Set Screw
1077c	1495	"	"	"	"	"	Spot Screw
95262	1016	"	"	"	"	"	Oil Cover
95307	1162	"	"	"	"	"	Stud
95335	1162	"	"	"	"	"	Bushing
447c	1495	"	"	"	"	"	Set Screw
RR68	1495	"	"	"	"	"	Roller and Screw Stud with 378c and 1520c
378c	1495	"	"	"	"	"	Screw
1520e	1025	"	"	"	"	"	Nut
92057	1491	"	"	"	"	"	Position Pin

No.	Plate						
95264	—	Machine Base
8294	1021	"	"	Hinge Connection
2809	1021	"	"	"	Pin
95265	—	Machine Base , complete, Nos. 95264, two each 2809 and 8294
95266	1016	Needle Bar with 95357
95267	1491	"	"	Bushing
443c	1024	"	"	"	Set Screw
95268	1016	"	"	Clamp with 552h
552h	1024	"	"	"	Thumb Screw
95269	1016	"	"	Eccentric with 449c
92071	1022	"	"	"	Dowel Pin
92275	1493	"	"	"	Fork with 157c
157c	1024	"	"	"	Clamping Screw
92276	1493	"	"	"	Strap
208c	1495	"	"	"	"	Screw	...
92277	—	Needle Bar Eccentric Fork , complete Nos. 92275, 92276 and two 208c
449c	1024	Needle Bar Eccentric Set Screw
95357	1162	"	"	Thread Guide
95272	1017	"	"	"	Nipper
95273	1020	"	"	"	Roller
1342c	1024	"	"	"	"	Screw Stud	...
95274	1020	"	"	Guide with two 95275
181d	1024	"	"	"	Binding Screw
95275	1020	"	"	"	Position Pin
2007	1022	Reel Pin (2)
2102	1017	Tension Disc
SS410f	1024	"	"	Screw Stud and Thread Guide
331d	1024	"	"	"	Set Screw
1560d	1025	"	"	"	Thumb Nut
95276	1022	"	"	Spring
95277	1022	Thread Guide (for front of machine)
95278	1020	"	"	"	"	"	(for E'port only)
95279	1014	"	"	Nipper Bar
95280	1016	"	"	"	Connection
1155d	1024	"	"	"	Binding Screw
95281	1491	"	"	"	Eccentric with SS119c
95282	1017	"	"	"	Fork
95360	1494	"	"	"	Collar with 704c
704c	1495	"	"	"	Clamping Screw
95284	1016	"	"	"	Connecting Link

From the library of: Diamond Needle Corp.

No.	Plate	Thread	Nipper	Bar	Eccentric	Fork	Connecting	Link	Hinge
95d	1024								Screw (2)
SS119c	1024	"	"	"	"				Set Screw
95285	1022	"	"		Spring			
197f	1024	"	"		"	Screw		
95286	—	"			Take-up	Post		
95287	1022	"	"		"	95286 with NN77d		
NN77d	1025	"	"		"	Thumb Nut		
92093	1022	"	"		Spring			
95289	1022	"	"		"	Collar		
95290	—				Thread Take-up , complete, Nos. 92093, 95287 and 95289			

PARTS SPECIAL

TO

No. 46K30 Machine



For Glove Work. This machine is similar to the No. 46K29 but possesses a greater capacity for heavier work.

This machine is the same as No. 46K29, with the following exceptions.—

No.	Plate								
95291	—	Cover Plate , complete, Nos. SS410f, 8645, 95213, 95290, 95292, two each 331d, 1560d, 95276 and four 2102
95292	1021	Flat Thread Guide Finger
92265	—	Head (of machine)
95245	1021	Looper with 92057 (single chain)
95293	1021	" " 92057 (double chain, fine)
95393	1162	" " 92057 (" " coarse)
NOTE—No. 95293 is supplied with this machine unless another Looper is specified on order.									
92278	1494	Looper Holder Rock Shaft Bracket (right side)
92279	1494	" " " " " " (left side)
92280	1491	" " " " Stud
92281	1491	" " " " " Bushing
92282	1491	" " " " " Collar with 704c
704c	1495	" " " " " Clamping Screw
95297	1016	Needle Bar with 95357
95298	1021	" " Thread Nipper
95299	1015	" " " " Spring
95300	1021	" " " " Adjusting Bracket
904c	1024	" " " " " " " " Set Screw
95340	1162	Thread Nipper Spindle
171c	1024	" " " Binding Screw

From the library of: Diana D. Needle Co.

ACCESSORIES

No.	Plate	
46 x 5	—	Needles, 3 each sizes 4 and 5, for 46K29 Machine
46 x 5	—	" 3 " " 5 " 7, " 46K30	"	...
36569	—	Oiler
25537	—	Screw Driver
86405	1021	Tweezers
—	—	Wood Screw 1½ x ¼" (3)

KNEE LIFTER

No.	Plate	
2767	1023	Knee Plate with 356c
92464	1023	" " Arm
2766	1023	" " " Bracket with 356c
356c	1495	" " " " Set Screw
356c	1495	" " Set Screw
92465	1023	Lifting Lever
95302	—	" " 92465 with 180d, 210d, SS345e, 92466, 92469 and 95303
SS345e	1023	" " Hinge Screw
92466	1023	" " Bracket
—	—	" " " Screw (Wood) 1" No. 10
92008	1023	" " Connecting Rod
92009	—	" " " " 92008 with 6337
6337	1023	" " " " Bracket with two 356c
356c	1495	" " " " " Set Screw
95303	1023	" " Releasing Pin
95304	1023	" " " " Guide Plate
—	—	" " " " " " Screw (Wood) 1" No. 10
180d	1023	" " " " " Set Screw
92469	1023	" " Stud
210d	1023	" " " Position Screw
92470	1023	Rock Shaft
92471	—	" " 92470 with 2766, 2767, 92009 and 92464
82479	1023	" " Bracket
—	—	" " " Screw (Wood) 1" No. 10
95305	—	Knee Lifter, complete, Nos. 92471, 95302, 95304, two 82479 and nine Wood Screws 1" No. 10

OBSOLETE PARTS

No.	Plate								
95248	---	Looper Holder for 95249
95249	1491	"	"	95248 with RR65
95256	1491	"	"	Rock Shaft Bracket	(right side) for 46K29 Mch.				
95257	1491	"	"	"	"	"	"	(left side) for 46K29 Mch.	
95294	1020	"	"	"	"	"	"	(right side) for 46K30 Mch.	
95295	1020	"	"	"	"	"	"	(left side) for 46K30 Mch.	
95331	1162	"	"	"	"	Eccentric with two 446c, for 46K30			Machine
95359	1162	"	"	"	"	"	"	with two 446c for 46K29	Machine
95260	1491	"	"	"	"	Fulcrum Joint Stud
95336	1162	"	"	"	"	Stud Collar with 704c, for 46K30			Machine
RR65	1025	"	"	Roller and Stud for 95249
95408	1493	Needle Bar Eccentric Fork Strap
175c	1495	"	"	"	"	"	"	Screw	...

From the Library of: Diamond Needle Corp